

PC LENS FOR WINDOWS AND DOORS APPLICATIONS

MATERIAL INFORMATION

Product Type	Windows – Doors Lens
ROHS compliant	Yes
Product Material	PC
Colour	Clear
Warranty	5 Years

TECHNICAL INFORMATION

Size (mm)	Φ68.49*14.05
Fastening	Glue / Silicone Gasket

DIMENSIONS

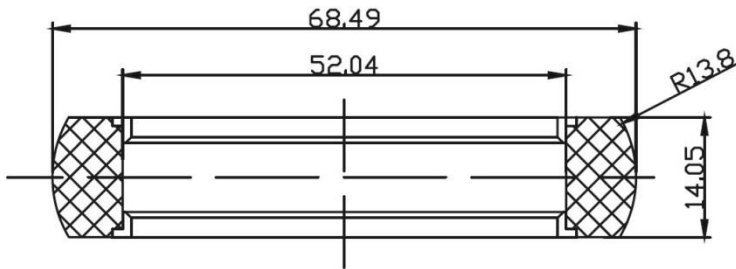
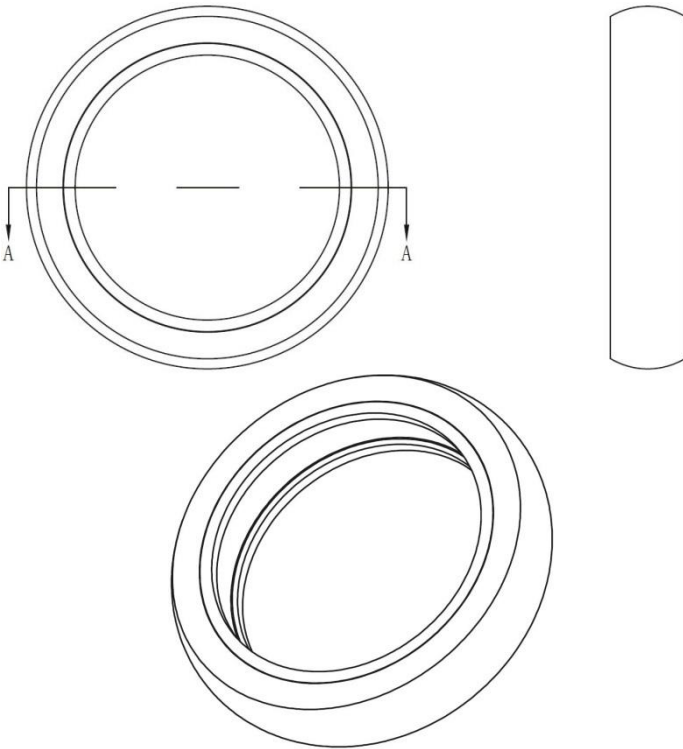

OPTICAL INFORMATION

LED	3535
Beam Angle(FWHM)	3*360°

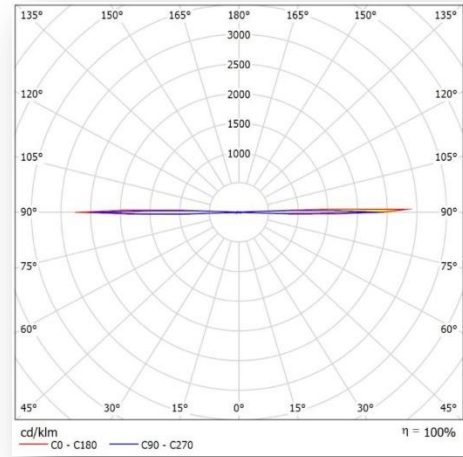

-Light Distribution Curve

LED MODULE LAYOUT

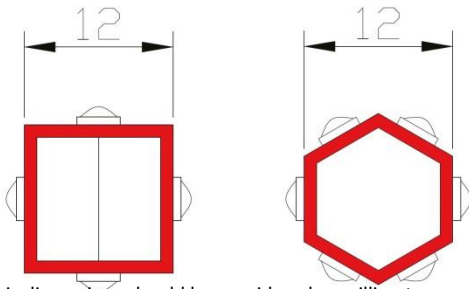

*This dimensions should be considered as millimeter

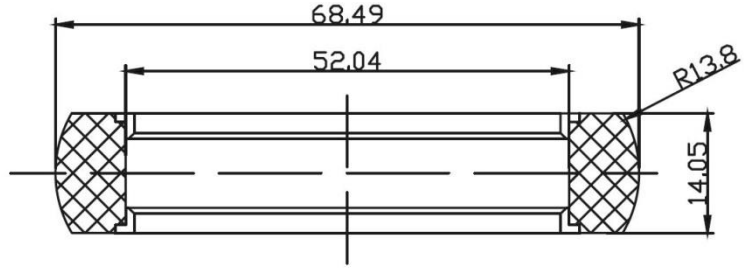

FIELDS OF APPLICATION

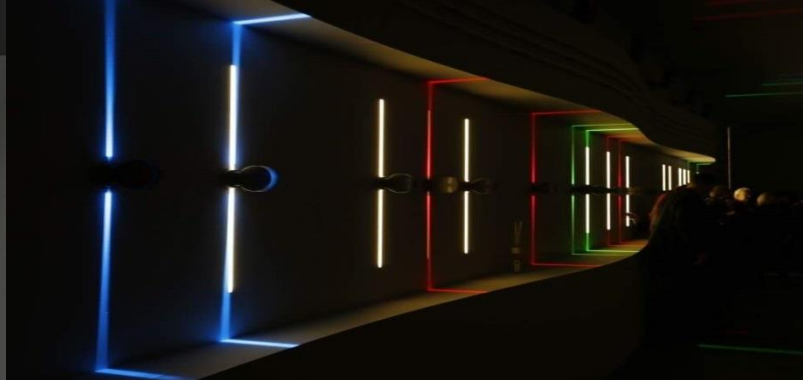
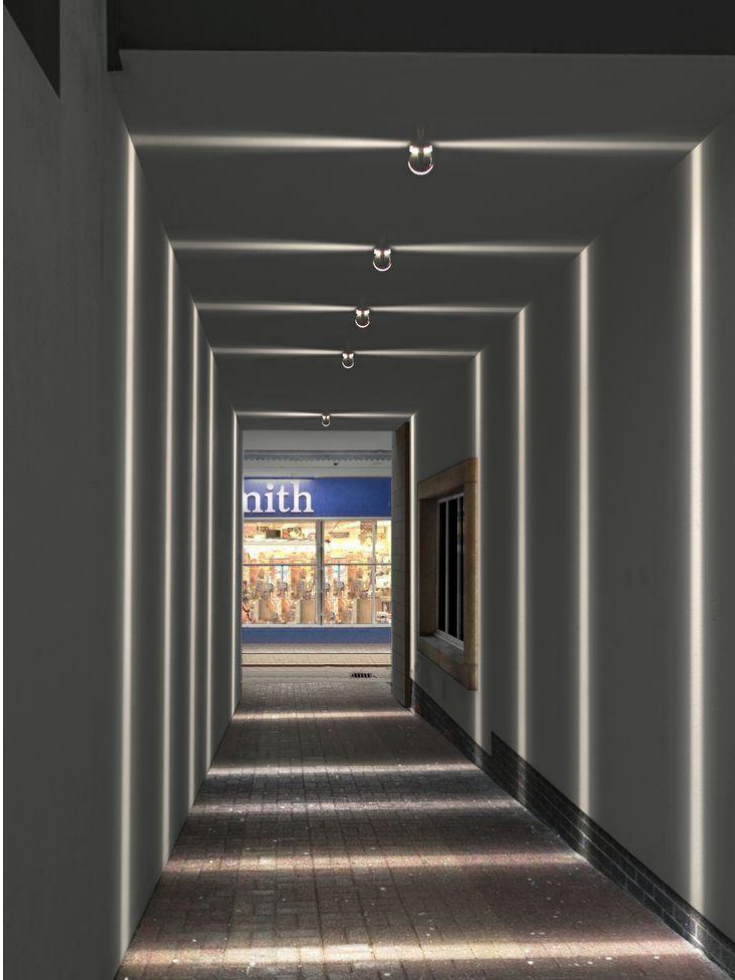
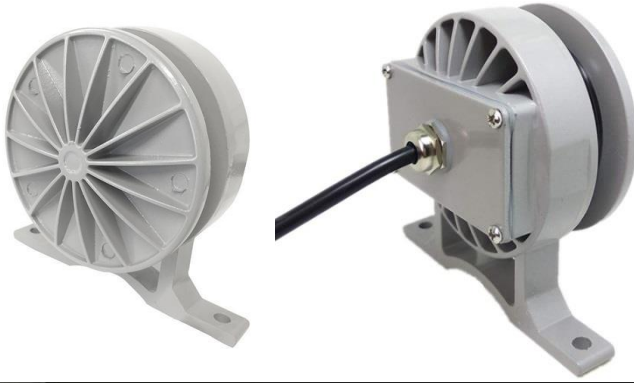

ATTENTION

- Storage: Do not store in dusty place, or expose under corrosive environment.
- Contact: Do not touch the lens surface with bare-hand. Please use gloves to touch the lenses.
- Cleaning: Clean lenses only if necessary. Use only mild soap, water and soft cloth. Do not use any commercial cleaning solvents
- The temperature of the lens in the working environment is controlled at -40°C ~ +120°C.
- Storage environment requirements, temperature: 0°C ~ 40°C humidity:30% ~ 95%.
- Before use the lens, don't open the package to avoid dust pollution.
- Avoid direct sunlight to avoid aging, discoloration, fission and other adverse effects.
- Do not use acidic or alkaline solvents to touch the product to avoid chemical reactions.

ORDERING INFORMATION

Order Code	FLS-PC-D0068006814-SBA03360
Qty in Small Box/MPQ	16
Small Box Size (mm)	125 x 125 x 130
Small Box Weight (kg)	0.505
Qty in Box	288
Box Size (mm)	400 x 400 x 290
Box Weight (kg)	9.1

